



Hero Me Gen7

Parts Selection and Assembly Instructions



**WHEN IT COMES TO COOLING
EVERYBODY DESERVES A HERO!**

Exclusively for Hero Me Gen7 Patrons

Hero Me Gen7

Parts Selection and Assembly Instructions

Table of Contents:

Hero Me Gen6 Introduction and Background	Page 3
3D Printers, Hotends, Extruders, Fans, ABLs Supported	Page 4
Regarding Your Choices with Part Cooling Fans	Page 6
Additional Hardware Required to Assemble the Hero Me Gen7	Page 7
Hero Me Gen7 Naming Conventions	Page 9
Hero Me Gen6 Parts Cross-Reference	Page 12
Hero Me Gen7 STL Parts Orientation	Page 14
Required and Optional Parts for a Hero Me Gen7 Setup	Page 16
Hero Me Gen7 Parts Selection	Page 18
Hero Me Gen7 Basic Assembly	Page 20
ABL Sensor offsets for Firmware or GCODE	Page 34
3D Printer Model Specific Notes	Page 35
Hero Me Gen7 Orientation and Assembly Videos	Page 36
Thanks and Credits	Page 36

Hero Me Gen7 Introduction and Background

Welcome and thank you for selecting the Hero Me Gen7 cooling system for your 3D printer. The Hero Me was originally designed by Marcelino A. Mosquera S. (Kelokera) from the Dominican Republic and posted to Thingiverse.com in September of 2018. release.

By end of 2018 Marcelino was no longer active on Thingiverse, and not responding to questions and requests from the community. Seeing great feedback and interest from the community, I created my first full remix of the Hero Me (Gen2) in January 2019. Later in 2019, I was able to connect with Marcelino and he gave me his approval to take over the Hero Me project. Now 4 years on I continue to update the Hero Me and add support for new printers, hotends, ABL sensors and other addons.

The key design concepts behind the Hero Me is to provide superior part cooling performance and to make a system that is modular, to support different brands and models of printers, hotends, direct drives, fans, ABLs, and other addons. This core modularity has allowed for the creation of over 650 different addons and remixes across the community in the years since.

Now seven generations later, the Hero Me Gen7 continues with these key design guidelines. The Hero Me Gen7 has maintained backward compatibility for most of the parts for Gen5 and Gen6. The flexibility of the Hero Me Gen7 also makes it future proof, as it also supports new tool changing systems, including the Wham Bam MUTANT, PrinterMods Xchange, and the BigTreeTech HermitCrab as well as the newly popular Orbiter and Sherpa direct drive extruders among many others. The Hero Me Gen7 is one of the top 2-3 aftermarket part cooling systems available on the Internet, now with over a half million downloads.

Hero Me Gen7 simplifies assembly and make future hotend maintenance and/or upgrades much easier by using threaded heat pressed inserts (no more M3 nuts to deal with). The HMG7 suite of parts will be compatible with future Hero Me releases and generations.

The instructions below will help you to select the parts needed for your printer as well as guide you through printing, assembly, and setup to be able to make great things with the Hero Me Gen7 and your 3D printer. This is the third generation of this document. While it has been significantly improved, I am sure there is lots of room for improvement. If you find any discrepancies or have suggestions on how this manual for the Hero Me can be further improved, please send them to me at: mediaman3d@gmail.com.

If you do not find your specific printer/model, hotend, direct drive, ABL, or other setup covered in this document, check out the Remixes tab of the Thingiverse project or my Thingiverse and Printables.com collections of Hero Me compatible designs, as there are now over 650 remixes, adaptations, and compatible add-on parts for the Hero Me Gen7.

<https://www.printables.com/model/39322-hero-me-gen7-master-suite>
<https://www.thingiverse.com/mediaman/collections/hero-me-cooling-systems>

If you like my work, please consider supporting my work via Patreon or these other services. Thank You and Happy Printing! Andy aka MediaMan3D

<https://www.patreon.com/MediaMan3D>
<https://www.buymeacoffee.com/MediaMan3D>
<https://www.youtube.com/@MediaMan3D>

Hero Me Gen7 Parts Selection and Assembly Instructions

This is an initial version that is being edited and expanded. The next update will include rendered images and photos. Please provide feedback on this document or anything else Hero Me Gen7 related via the #hero-me-gen7 or #hmg7-support channels in the Hero Me Discord server. Be sure to review the #gen7-faqs channel first before posting your question as it may already be answered.

3D Printer Models Supported by the Hero Me Gen7 Master Suite

This is a continually growing list of 3D printers that are compatible with the Hero Me Gen6 and Gen7. Many more 3D printer brands and models are supported by the community in either the remix section or in my collection of Hero Me compatible designs found on [Thingiverse.com](https://thingiverse.com) or [Printables.com](https://printables.com).

Other manufacturer's clones of the Creality CR and Ender series printers that are not listed below may be compatible but have not been tested.

<p>3DFused V1, V2, V3, CoreXY Anet ET4, ET5, A8 Anycubic Vyper, Chyron, Mega Zero Creality CR-10 CR-10 V2, V3 CR-10 Mini CR-10S CR-10S4 CR-10S5 CR-10S Pro CR-10S Pro V2, V3 CR-20 CR-MAX Creality Ender 3 Ender 3X Ender 3 V2 Ender 3 Pro Ender 3 MAX Ender 5 Ender 5 Pro Ender 5 Plus ENDER 6 CoreXY Most clones of CR and Ender</p>	<p>Elegoo Neptune 2, 2S, 3, X Exoslide Geeetech A10, A20, A30 Kywoo Lantro Longer LK5 Pro OpenBuilds Mini Sovol SV01, SV02 Sunlu S8 Tevo Tarantula Pro, Tornado Tronxy X5SA Pro Two Trees Bluer, Sapphire Pro Voron Switchwire Voxelab Aquila-Pro ZYLTech Gear V3 3DFused X Axis upgrades BLV Ender 3 Linear Rail Upgrade Micro Swiss DD kit, Ender 3, 5, Linear Rail, Exoslide BigTreeTech HermitCrab PrinterMods Xchange & MDD kit V1.2, V1.3 Wham Bam MUTANT Wham Bam Universal X carriages Linear Rails MGN9-H, MGN12-C, MGN12-H</p>
--	--

Hotend Brands and Models Supported:

- Creality OEM (2 screw mount)
- Creality CR-10S Pro (2 screw mount)
- Creality Spider High Temp
- Creality Spider 2 & 3 Pro
- MK8
- Micro Swiss All Metal
- E3D-Online V6 & Volcano
- E3D-Online Revo Six
- E3D-Online Revo Micro
- E3D-Online Revo Voron

- E3D-Online Revo Creality
- Slice Copperhead
- Slice Mosquito
- Slice Mosquito for Creality
- Phaetus Dragon (2 screw mount)
- Phaetus Dragon (grove mount)
- Phaetus Dragonfly BMO
- Phaetus Dragonfly BMS
- Phaetus Dragonfly HIC
- Phaetus Rapido HF, UHF
- Phaetus TaiChi
- Clones of any hotends above (note: look-alikes may not fit, just true clones)
- Bondtech BMG (and mirror)
- Bondtech BMG-M
- BMG Mini (clone)
- Bondtech LGX
- Bondtech LGX Lite
- Orbiter V1.5 & V2.0
- Sailfin
- Sherpa Mini
- Sherpa Micro
- Micro Swiss DD Kit
- PrinterMods MDD Kit
- Smartwatch Clockwork
- Voron Afterburner
- Voron Stealthburner
- Clones of any extruders above (note: look-alikes may not fit, just true clones)

Auto Bed Level (ABL) Sensors Supported:

- BLTouch
- EZABL Pro
- EZABL Pro Mini
- PINDA
- CR Touch
- HallON
- Touch Mi
- TA sensor
- Omron sensor
- 8mm, 12mm & 18mm sensors
- Clones of any ABL sensors above

Direct Drive Extruder Brand and Models Supported:

- Creality stock Single and Dual gear
- Sovol SV01 stock
- E3D-Online Titan

The first release of the Hero Me Gen7 STLs supports:

68 3D Printer models (plus clones)
 22 Hotends
 18 Extruders (27 mount options)
 12 ABLs

45 Part Cooling Duct options
 10 Cable Management options
 5 ADXL345 mounts
 4 LED bar mounts

Where Hero Me Gen6 had over 285 million possible 3D printer setups supported, Gen7 supports OVER 1 BILLION possible 3D printer setups! And Hero Me Gen7 has 47% fewer total STLs than Gen6 (293 STLs for Gen7 vs. 478 STLs for Gen6). Never fear, the Gen7 is a breeze for part selection.

Heat Sink and Part Cooling Fans Supported:

- 4010 radial (single and dual)
- 4020 radial (single and dual)
- 5015 radial (single and dual)
- 5020 radial (single and dual)
- 4010 & 4020 axial fans for heat sink cooling

Regarding Your Choices with Part Cooling Fans

The Hero Me Master Suite is all about being able to custom match most any set of print head components AND provide the best part cooling.

All my Hero Me printers have dual 5015 fans & dual ducts. This is my recommendation for everyone upgraded their printers to get the most performance and flexibility out of the Hero Me Gen6-7 systems. But at a minimum, use a single 5015 fan.

The 4010-, 4020-, and 5020-part cooling ducts are all because of maker requests, as that is all they had. While 4020 and 5020 radial fans are acceptable, I DO NOT recommend using the stock 4010 fan from your 3D printer. 4010 fans do not produce enough static pressure to properly drive dual ducts, and a single duct 4010 will not properly cool the part as it only covers one side.

A major reason for upgrading to the Hero Me is to get excellent part cooling. Re-using the stock 4010 fan will not do this. I also do not recommend (or support) axial fans for part cooling (not enough CFM).

With dual 5015 fans (or any dual fan setup), never run them at 100% power. With a dual 5015 setup, you run the fans for normal printing at 40-45% power. This still gives you 3X the CFM (airflow over a stock 4010) AND it is all directed properly at the part below the nozzle.

The extra benefit is that they run whisper quiet. When you have extreme overhangs, or long bridges, set the fans power to 65-70%. 4020 and 5020 fans will work just fine, you just need to run them at slightly higher power settings (5020s generally do not produce as much static pressure as 5015s).

For great proof of what dual 5015's can do in a Hero Me setup, check this YouMakeTech YouTube video of an older Gen5 setup can do bridging 250mm with no supports and no sagging! While the whole 9-minute video is worth watching, the bridging starts at 8:05. <https://youtu.be/Cz-Ag0OTL7M>

The best fans around are Sunon Maglev fans, but they are hard to find and 4X as expensive as the average fans. They can be \$18 each vs. two for \$9 on Amazon. When buying part cooling fans, be sure to look for fans that have the following in the description: "brushless, sealed, dual ball bearing". Do not buy fans that have 'hydraulic' in the description, as those need to be lubricated regularly.

Most of my printers are built with Winsinn fans. Here are two links to where the fans can be purchased:

Sunon: <https://spool3d.ca/sunon-5015-radial-centrifugal-fan/>

Winsinn: <https://www.amazon.com/WINSINN-Bearings-Brushless-Cooling-50mm15mm/dp/B08R9G2VDR>

Additional Hardware Required to Assemble the Hero Me Gen7

The Hero Me Gen7 system uses M3 screws and M3 threaded inserts to secure all the components together and mount it to your printer’s X carriage. You will need a soldering iron (preferably with an insert tip) to install the inserts into the Hero Me parts. The specifications are as follows:

M3 threaded inserts: 4.6mm outer diameter by 4mm length ← Preferred. Note that 3mm – 5mm lengths are acceptable.

The common M3 inserts with 5.6mm lengths are TOO LONG, do not use them as they will interfere with mounting the hotend and other components.

M3 threaded inserts Quantity: 35-50 inserts per Hero Me Gen7 assembly.

M3 screws Quantity: As there are over 1 billion possible combinations of Hero Me Gen7 components, I cannot know the total number of M3 screws or what sizes any given Hero Me Gen7 setup will require. I recommend that you purchase (if you don’t already have a selection) an M3 screw assortment box that has M3 hex socket head or button head screws from 6mm to 30mm lengths.

Here is an example of the type of M3 threaded inserts to use:

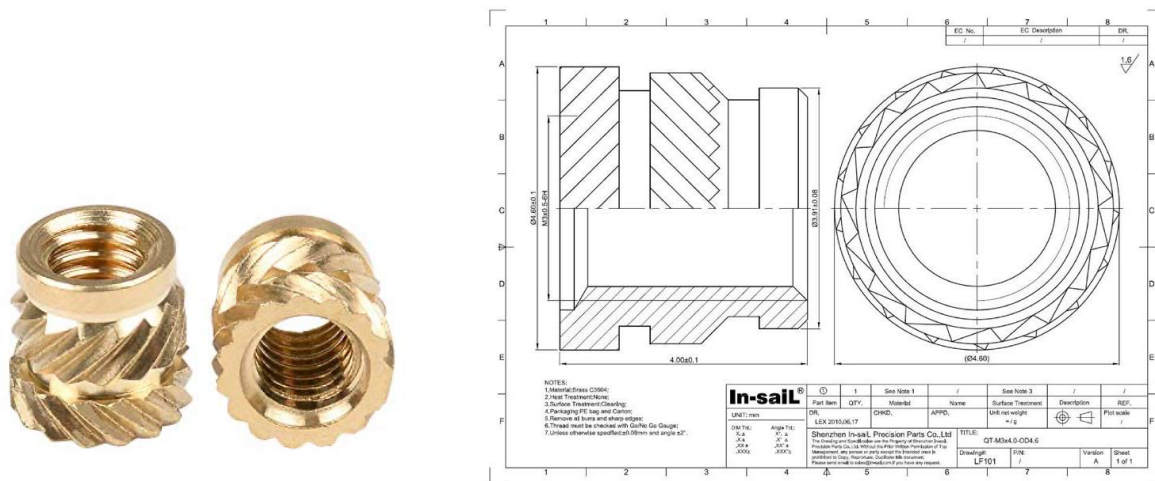

Note that they do not have to be the brand shown above.

Here is an example of the type of M3 screw assortment kits to use:



Here are links to sources for M3 screws and threaded inserts:

- KB3D. A bit expensive (sold by the piece) but the perfect size: kb-3d.com/store/inserts-fasteners-adhesives/97-brass-heat-set-threaded-insert-for-plastic-m3x46x4mm.html
- Fabreeko. A little longer than I like, but still works: fabreeko.com/collections/v2-4/products/threaded-heat-inserts-m3x5x4-100pc-per-bag
- Amazon. Perfect size, 100pcs.: <https://www.amazon.com/dp/B08T7M2H4S>
- Amazon. Perfect size, fewer pieces (more than enough for a couple Hero Me setups) but also includes a proper tip for a soldering iron: amzn.to/3nMnSsJ
- CNC Kitchen EU. Perfect size, 100pcs: <https://cnckitchen.store/Gewindeeinsatz-threaded-insert-M3-Short-100-Stk-pcs-p431146045>
- Prusa3D. EU. Perfect size, 100pcs: <https://www.prusa3d.com/product/threaded-inserts-m3-short-100-pcs>
- (Amazon Italy) 100pcs: <https://www.amazon.it/gp/product/B09ZHSGHXD/>
- Amazon US: 300PCS M3 Hex Socket Head Cap Screws Assortment Set Kit with Storage Box: <https://www.amazon.com/Stainless-Screws-300PCS-Assortment-Storage/dp/B094NHTRL5>
- Amazon US: 1350 Pcs M3 x 4/5/6/8/10/12/14/16/18/20/25/30 Stainless Steel 304 Hex Socket Head assortment: <https://www.amazon.com/iexcell-Stainless-Socket-Washers-Assortment/dp/B09XN629BF>

Hero Me Gen7 Naming Conventions

HMG7 – Hero Me Gen7

Hero Me Base – Core component of the Hero Me system with standardized mounts for hotend, fans, extruders, ABL sensor, ADXL345 and other components.

Stack – A term referring to the way a Hero Me holds the hotend and direct drive extruder. The Base is the platform, then a hotend mount 'stacks' on top of the Base. If an extruder is used, the direct drive mount is then stacked on top of the hotend mount. Each of the component STLs have 'lego pins' to ensure proper alignment of the components for the filament path to be straight. These are then secured together with two M3 screws.

ADXL345 – PCB based accelerometer used with Klipper firmware to calibrate a 3D printer

X carriage or **Gantry Plate** – Metal plate that the hotend assembly mounts to on the X axis.

Gantry Adapter – the plate that marries the Hero Me Base to the X carriage of the 3D printer.

Gantry Clip – A small part that is used in some setups to help retain the Gantry Adapter to the X carriage because there are not enough mount points provided. Most all Gantry Clips are aligned on the right side of the X carriage from the back and line up to a mount point on the Gantry Adapter. The Gantry Clip for an Ender 5/Pro/Plus fits in the vertical slot of the X carriage from behind and lines up with two of the four mount points for the Hero Me Base and Gantry Adapter.

Part Cooling Duct – fans attach to this part to cool the printed part below the nozzle

DD – Direct Drive extruder

ABL – Auto Bed Level sensor

EZABL – An ABL sensor from TH3D Studios

E3D – E3DOnline hotend manufacturer

V6 or **E3DV6** – E3D Online hotend (collar mount)

'V6 Style' – Creality hotend for the CR-10S Pro that looks like the E3D V6 but mounts with 2 screws horizontally

Volcano – E3D Online hotend (high flow, tall)

Clone – a copy of a name brand/model of 3D printer part

Collar or **Groove** – The type of mount used by E3D V6 hotends and clones

Revo Six, Revo Micro, Revo Voron – E3D Online hotend

MK8 – standard hotend used by Creality (two screw horizontal mount)

MS – Micro Swiss All Metal hotend (MK8 clone)

Mosquito – Slice Engineering hotend (two screw top or collar mount)

Copperhead – Slice Engineering hotend (two screw top or collar mount)

OEM or **Stock** – used in reference to the stock part that came with the 3D printer

BMO – Phaetus Dragonfly BMO hotend (two screw horizontal mount)

BMS – Phaetus Dragonfly BMS hotend (collar/groove mount)

HIC – Phaetus Dragonfly HIC hotend (two screw mount, thicker heat sink)

Dragon – Phaetus Dragon hotend (Mosquito clone) (two screw top or collar mount)

Spider, Spider 350, Spider Pro – Creality Spider high temperature hotends (collar or two screw horizontal mount)

Rapido – Phaetus Rapido hotend (Revo Six clone) collar mount

HF or **UHF** – Phaetus Dragon high temp, high flow hotends

XY Offset – a distance measured in mm. Often used to calibrate the position of an ABL sensor in relation to the nozzle of the hotend. Also used to set the Home position of the hotend via GCODE commands or instructions in the firmware of the printer.

OEM-MK8-MS-MSDD-BMS – Used in STL filenames. The STL is for use with hotends that match one of these types (or a clone of one).

E3DV6-Revo Six-Spider-BMO - Used in STL filenames. The STL is for use with hotends that match one of these types (or a clone of one).

Tall – Used in STL part cooling duct filenames. STLs with this attribute are for use with very tall hotends (e.g. Rapido UHF, E3D-Online Volcano, etc.) These ducts are too tall for most hotends.

Long – Used in STL part cooling duct filenames. STLs with this attribute are for use with very specific printer setups when called for in the documentation (e.g. Micro Swiss DD kits, Neptune 3). These ducts should not be used for any other configurations, as the duct tips will be out of alignment with the nozzle.

Brace – Used in STL part cooling duct filenames. STLs with this attribute have a brace ring that connects to both fan mount points

Lightweight – Used in STL part cooling duct filenames. STLs with this attribute are lower weight versions of the other equivalent ducts.

Forward – Used in STL part cooling duct filenames. STLs with this attribute have the fan moved forward more than other equivalent ducts. This enables a BLTouch or CRTouch to be mounted

behind the left duct to be closer to the nozzle to improve the mesh created from leveling the bed.

Dual - Used in STL part cooling duct filenames. STLs with this attribute use two fans.

Single - Used in STL part cooling duct filenames. STLs with this attribute use one fan.

Front - Used in STL direct drive mount filenames. The stepper motor will face the front of the printer

Rear - Used in STL direct drive mount filenames. The stepper motor will face the back of the printer

Mirrored - Used in STL direct drive mount filenames. The extruder is a mirrored (left hand) version from the vendor.

Riser – Several sizes of spacer STL used to raise the position of a rear facing direct drive extruder to clear the top of tall X carriages (optional). Available in 4mm, 6mm, and 10mm. Multiples can be used if needed.

Mount - Used in STL filenames to denote that this part holds the component that is referenced in the filename. When used for ABL sensors the Mount STL holds the ABL sensor and connects directly to a Wing. This part controls the height of the ABL sensor in relation to the nozzle on the Z axis.

Wing/Bracket - Used primarily in STL ABL and filenames. The Wing or Bracket STL connects directly to the Base on the back left or back right side behind the part cooling duct mounts. This part controls the distance an ABL sensor is from the nozzle. Different widths (Compact, Close, Narrow, Standard, Medium, and Wide) are provided to ensure that space is made available based upon which Part Cooling duct(s) are used.

Cable Tower – Hotend/Extruder/Fan wire management – A pole with many mount points for zip ties to hold the power wires for the various components on the Hero Me.

Hero Me Gen6 Parts Cross-Reference

Parts Cross Reference Preparation

If you have not already, download the latest release ZIP of the Hero Me Gen7 STL library from this Patreon post (It will always be the most current, as well as nicely organized in folders/sub folders by category and type of STL): <https://www.patreon.com/posts/hero-me-gen7-1-0-74115568>

Answer the following questions as they will guide you in selecting the STLs you need to print for your Hero Me Gen7 upgrade.

Questions About Your 3D Printer Setup (to help you know what to select)

Below are the questions about your 3D printer setup that you need to answer in order to use this guide to select the STLs you need to print for your Hero Me Gen7 upgrade.

1. What 3D Printer brand and model? (E.G. Ender 3 V2, CR-10S Pro V3, Neptune 2, Voxelab Aquila, etc. etc.). _____

2. Is your 3D printer's X carriage non-stock? (Yes ____, No____)

If No, skip the next question. If the answer is Yes, the answer to the next question overrides question number one above, as this is used to identify the Gantry Adapter needed since the stock one is not being used.

3. What brand/ model of 3rd party X carriage will be used? (E.G. PrinterMods MDD, Micro Swiss DD kit, 3DFused (3 versions), BLV, Wham Bam Systems Universal X carriage (two versions), or other).

The answers from the above questions are used to select the Gantry Adapter you need.

4. What Brand/model of hotend are you using? (E.G. Creality stock, Phaetus Dragonfly, Slice Mosquito, Micro Swiss, E3D V6, etc. etc.) _____

5. Which of the following types of hotend are you using? (Type 1_____ or Type 2_____)

Type 1: Hotends that mount directly to the X carriage via 2 screws, like the stock hotend from Creality, Micro Swiss, MK8, Spider, Dragonfly BMS, and others. (Filenames include OEM-MS-MK8-BMS)

Type 2: Hotends that mount via a collar or some other fixture that attaches to the X carriage, like the E3D V6, Revo Six, Slice Mosquito, Copperhead, Spider, and others. (Filenames include: E3D V6-Revo Six-BMO)

If you answered, 'Type 1', skip the next question.

6. If you answered 'Type 2': If your hotend has more than one way to be mounted, which mount type will be used? (E.G. Groove/Collar mount, Top screws, etc.) _____

7. Will you be using a Bowden setup or a Direct Drive extruder? (Bowden____, Direct Drive____)
If you selected Bowden: Skip the next two questions as you now have the info to select the right Hotend mount.

If you selected Direct Drive:

8. Which direct drive brand and model will be used? (E.G. Bondtech BMG, LGX, LGX Lite, Orbiter V1.5 or V2.0, Sherpa Mini, Titan, Creality Single or Dual Gear, etc.) This is needed along with the next question to select the correct direct drive mount STL file. _____

9. Do you want the stepper motor to face the front of rear of the 3D printer? (Front____, Rear____)

Note that some printers have tall X carriages that prevent having the stepper in the back (Rear). Some printers with low enough X carriages may have other issues using a rear facing stepper (tight X axis to Z axis assembly where a stepper would hit the aluminum extrusion before allowing the nozzle to get to X0). These issues require the stepper to face the front (Front).

With the DD Brand/model and stepper orientation, you now have the info to select the Extruder Direct Drive Mount.

Next, the type and number of part cooling fans (This helps identify which part cooling ducts to use):

10. How many part cooling fans? (1 or 2) _____

11. What size Fan(s)? (4010, 4020, 5015, 5020) _____

12. Optional - What type of ABL sensor will be used? (E.G. BLTouch, CRTouch, EZABL, Pinda, TA sensor, etc.) _____

This helps identify the ABL sensor mounting part(s). The selection of ABL mount parts is also affected by which part cooling ducts are used, as the sensor needs to be positioned not to interfere with the part cooling duct. The variations of the ABL wings affect how far from the nozzle the ABL sensor is mounted. BLTouch and CRTouch require two STLs (wing and mount/bracket).

13. Optional - Will you be using an ADXL345 accelerometer for use with? (Yes____, No____)
ADXL345 adapters are in the Options folder.

14. Optional - Do you need a heat sink fan guard? If yes, there are several to pick from in the Options folder. Almost any 40mm fan guard can be used.

Additional support notes, a detailed FAQ and other info are on the Discord server for All-Access patrons (and above). If you have not already, link your Discord ID to your Patreon profile so that the Patreon bot can assign your role in the Hero Me Discord server.

If after using your answers to the questions above and the instructions that follow, you still have trouble selecting the parts you need, support is available to All-Access patrons (and higher tiers) on the Hero Me Discord server. If you are Documentation patron, it is just a \$2 upgrade to get access to full support: including orientation and assembly videos, detailed FAQ guide, access to the private Hero Me Discord server and direct support from the developers.

All Hero Me support is done via the Discord server. To get the fastest most accurate support for your specific setup, post a message in the #hmg7-support channel with your answers to the numbered questions above so that I (or another Hero Me community member) can promptly and accurately help you.

Hero Me Gen7 STL Parts Orientation

Hero Me Gen7 part selection in most cases is much simpler that with Gen6. First off, there is just one Hero Me Base (well two if have access and are using the Magnet Edition). All of the Hero Me Gen7 STLs are organized by part category and type. STL filenames contain the name of the specific components so it is easy to identify which ones you will need.

To help with your orientation to Hero Me parts, I have created a 22-minute video post on the MediaMan3D Patreon page available to All-Access tier patrons and above.

<https://www.patreon.com/posts/hero-me-gen7-stl-74555664>

For reference here are several ‘exploded’ diagrams with the Hero Me Gen7 components identified. Your specific setup may look different, but the component names and positions are all standardized.

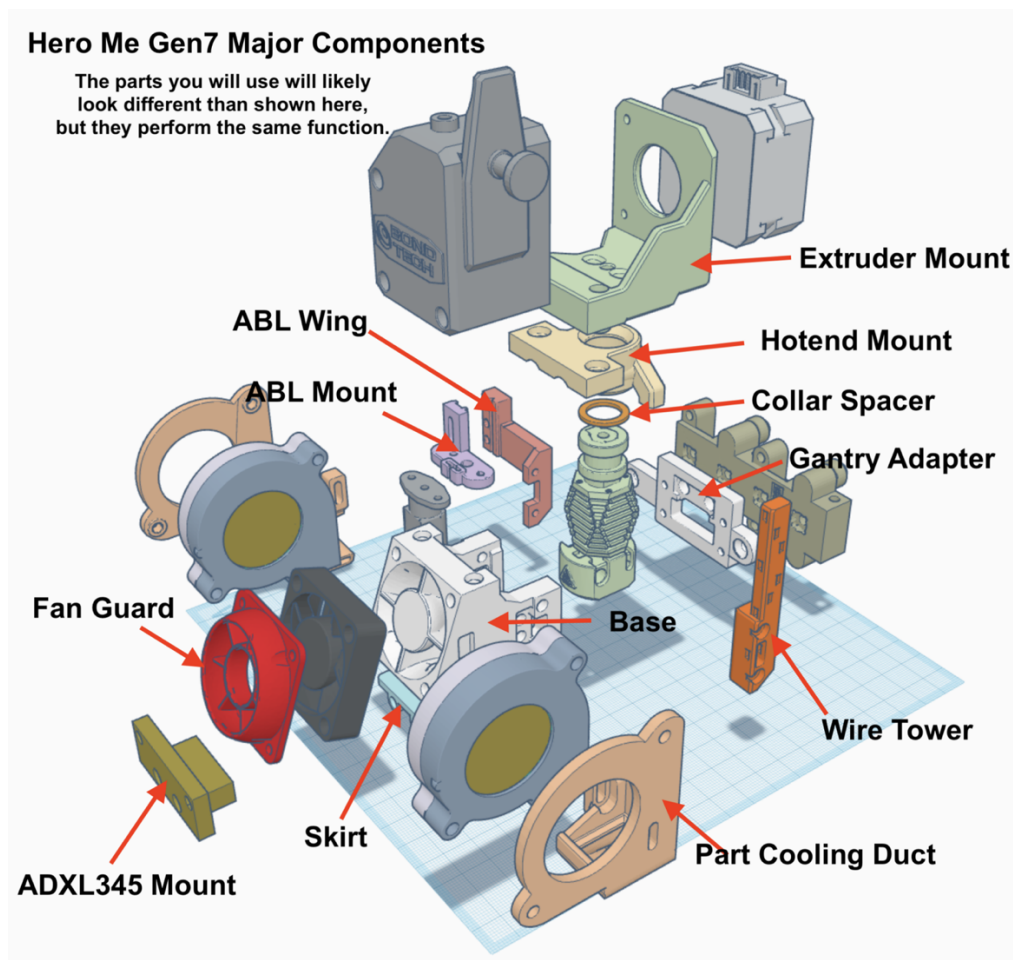

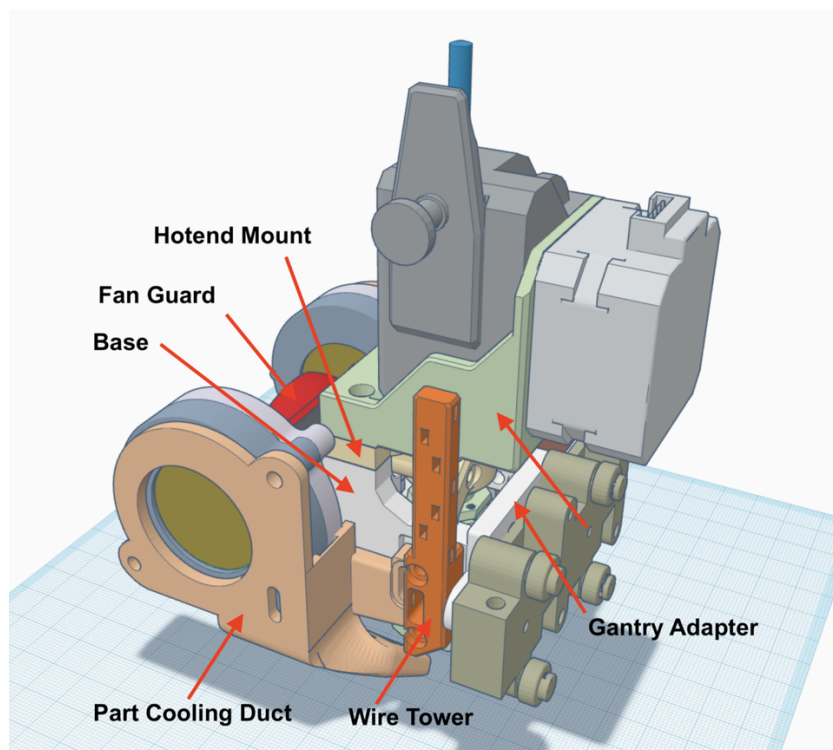
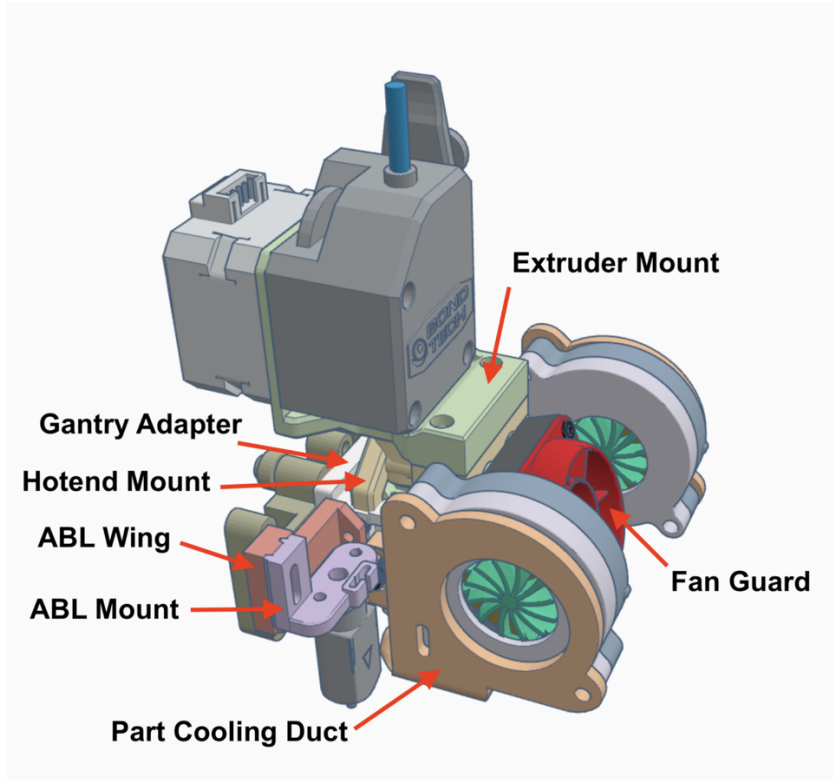

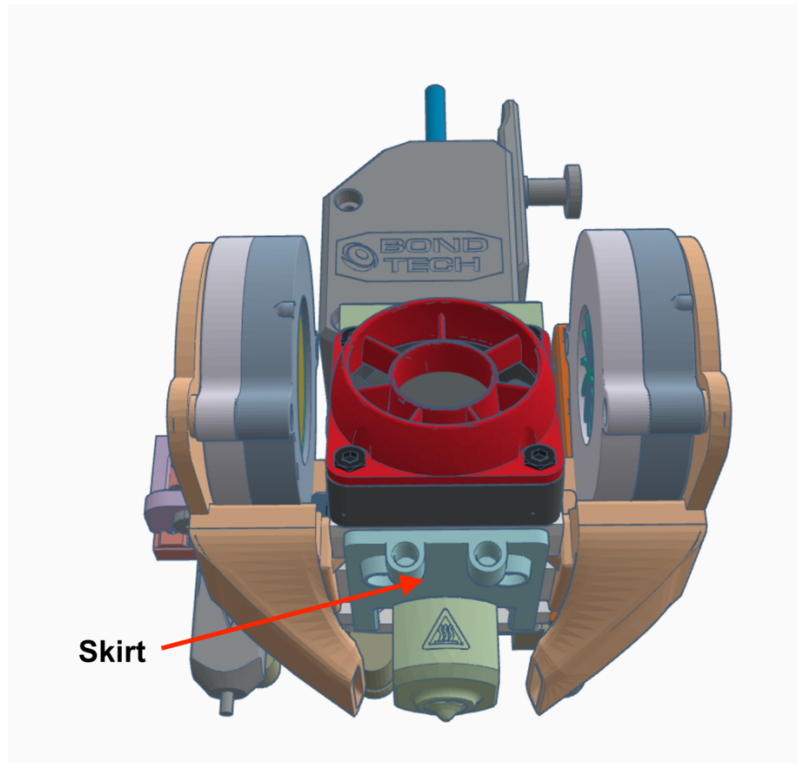

Required and Optional Parts for a Hero Me Gen7 Setup

All the STLs are organized in separate folders within the Hero Me Gen7 ZIP. You will need at least the following STL components:

- 1 Base
- 1 Gantry Adapter (that matches the model of 3D printer or 3rd party X carriage)
- 1 Hotend mount (that matches the hotend and mount type)
- 1- or 2-Part Cooling ducts (that match the size of part cooling fan(s))
- 1 Skirt (that matches the hotend being used)
- 1 Cable Tower

This is the basic setup for Bowden use. The following STLs are also needed for a direct drive setup:

- 1 Extruder direct drive extruder mount
- 1 or 2 Risers (or none in most cases)

The following STL components are OPTIONAL. They may be needed depending on your specific setup:

- 1 ABL mount and 1 bracket
- 1 Shroud for the heat sink fan
- 1 ADXL345 mount
- 1 LED mount

All the STL filenames are detailed with what model, type, size, orientation etc. for the type of component they are for. Look for your components' names or function in the STL filenames.

The ZIP of Hero Me Gen7 STLs is organized as follows (in alpha order):

- ABL Mounts (optional)
 - Gen6 Left Side ABL Mounts –
 - Gen7 ABL Brackets and Mounts –
- ADXL345 Mounts (optional)
- Base
- Cable Management
- Extruder Direct Drive Mounts (optional)
- Gen6 Gantry Adapters (for those printers that don't yet have a Gen7 version)
 - Micro Swiss DD Kits
 - Tevo
 - Two Trees
 - Misc.
- Gen7 Gantry Adapters
 - 3DDFused
 - Creality
 - Hotend-Gantry Standoffs (for some Bowden setups)
 - Linear Rails
 - Micro Swiss
 - Many more misc.
- Hotend Mounts
- Options
- Part Cooling Ducts
 - Long Ducts - Vyper-Kobra-Neptune 3-Micro Swiss Direct Drive
 - 4010 fans
 - 4020 fans
 - 5015 fans
 - 5020 fans
 - Standard Ducts
 - 4010 fans
 - 4020 fans
 - 5015 fans
 - 5020 fans
 - Tall Ducts - E3D Volcano-Phaetus Rapido-UHF
 - 4010 fans
 - 4020 fans
 - 5015 fans
 - 5020 fans

Hero Me Gen7 Parts Selection

Select the STLs you need from the unpacked Gen7 ZIP:

1. Get the Hero Me Gen7 Base STL. There are two to choose from, they are identical except for the orientation for printing. If your printer is very well dialed in (if you can print a clean and accurate 3DBenchy), then use the 'face' version. This does not need any support. Otherwise, use the 'upright' version, this one will require light supports from the build plate only. You need less support than you think!
2. Select the Gantry Adapter STL for your specific 3D printer model. Note that if you are using a 3rd party X carriage, tool changer, etc., then select the Gantry Adapter for that 3rd party upgrade. (Examples: Micro Swiss DD kits, 3DFused upgrades, Wham Bam MUTANT, BTT Hermit Crab, PrinterMods Xchange, and others). This is because the Hero Me system only cares about the X carriage it will mount to.

Important: If your 3D printer model is supported, but is not yet represented in the Gen7 Gantry Adapter folder, you can use the one in the Gen6 Gantry Adapter folder.

To make a Gen6 Gantry Adapter compatible with Gen7, you simply trim off the raised 2mm 'frame' on the left side that surrounds the ABL mount. See image below. Remove the portion in RED. This can be done in the slicer with a print blocker, or trimmed away after printing with an X-acto or other sharp knife. Soon, the remainder of these will be converted to Gen7 and released in an update.

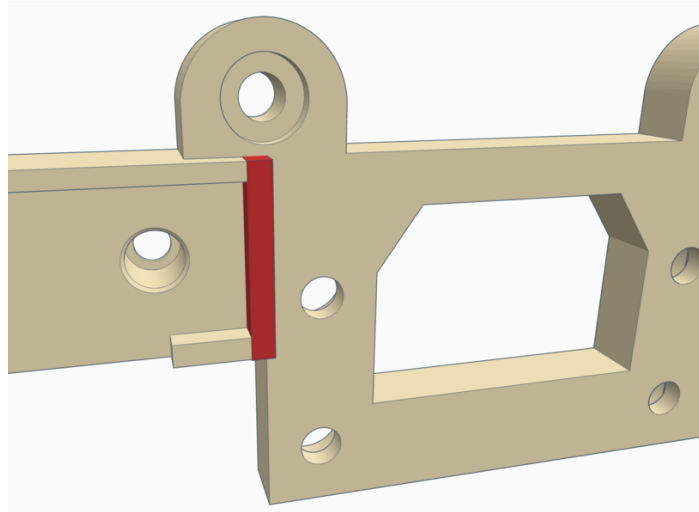

3. Select the Hotend Mount STL and Skirt STL that matches your hotend. If your hotend is not listing in the filenames and it has a collar mount option like the E3D V6, then you will use the collar mount with your hotend (HMG7 E3DV6-Revo Six-BMO Collar Mount V2.stl) along with one of the collar spacer STLs (start with the 1mm spacer).

The hotend is attached to the mount, and the mount is stacked on top of the Hero Me Base. The Skirt is mounted to the bottom of the Base.

4. Optional: Select an Extruder direct drive mount STL if you are going setup for Direct Drive use. There are both 'Front' and 'Rear' versions of most extruder mounts. This refers to the location of the stepper motor. Select the appropriate mount for how you want the extruder/stepper positioned.

The extruder and stepper are attached to this mount, and the mount is stacked on top of the Hotend mount. If you are using a rear facing extruder setup, and the stepper motor does not clear the height of the X carriage, you have two choices: 1. Use the front facing extruder mount instead. Or, 2. Print and add one or more Riser STLs as needed to clear the top of the X carriage. Risers are available in 4mm, 6mm, and 10mm heights.

5. Select the part cooling duct(s) STL(s) for the fan(s) you will be using.
 - a. The following 3D printers must part cooling duct STL(s) from the 'Long Ducts' folder:
All Micro Swiss DD kits
Anycubic Vyper or Kobra
Neptune 3
 - b. If you are using a very tall hotend (e.g. Phaetus Rapido) then you will be selecting your part cooling duct STL(s) from the 'Tall Ducts' folder.
 - c. For all other setups, Select the ducts from the 'Standard' ducts folder.

My recommendation for part cooling are dual 5015 fans to get the best performance from your Hero Me Gen7 setup. I use the 'Lightweight forward' ducts on all my setups.

6. Optional: Select the ABL wing & Mount/Bracket STLs for the ABL sensor you will use. ABLs can now be mounted on the left or right side of the Base. If the ABL sensor you have is not yet listed in the Gen7 folder, use the wing and mount for your ABL found in the Gen6 folder. There is an adapter bracket in that folder to allow attachment to the Gen7 Base. Soon, the remainder of these will be converted to Gen7 and released in an update.
7. Select one of the cable management tower STLs you want to use. There are both right and left side versions. The 5mm and 10mm widths are for direct drives that are too wide, otherwise preventing the cable tower to mount to the side of the base.
8. Optional – Select (or provide your own) heat sink fan guard from the Options folder. These are to protect the heat sink fan blades (and your fingers).
9. Optional – ADXL345, LED, and other mounts are provided in the Options folder as needed for your specific setup requirements. There are also over 650 add-ons and remixes available on Thingiverse.com and Printables.com that may meet your needs if you have a component that is not part of the Hero Me Gen7 inventory.

Hero Me Gen7 Basic Assembly

Print the parts you have selected.

The parts are pre-oriented for best print results. Most parts do not require supports, those that do, only need minimal support (you need less than you think) and most are build plate only.

Recommended printer settings for Hero Me STLs:

- Layer height: between .2mm to .28mm (lower is fine, but not required)
- Perimeters: 3 walls
- Infill: At least 35%.

If you use a silicone sock on your printer's hotend, you can use PLA+ for the Part Cooling ducts, Hero Me base, and Skirt STLs.

I highly recommend using a silicone sock for you hotend in all cases. I have printed for four years with the Hero Me made from 100% PLA+ with no warping or melting because I have always used a silicone sock.

If you do not have a silicone sock and are only printing PLA, PLA+, and PETG, then you must print the STLs in PETG (or higher temp filaments).

If your 3D printer is enclosed in a chamber, or you plan to print ASA, ABS, Nylon, or other high temp filaments, then you must print the Hero Me parts in at least ASA or ABS.

Only use automatic support settings from the build plate only. I highly recommend for the few STLs that require support, to manually place the supports. Be sparse, you will need less than you think.

The Part Cooling ducts only need support for the overhangs and just in front of some ducts. Do not place supports inside the tubes of the part cooling ducts.

Clean and trim the parts as needed, then install the threaded inserts.

Test fit all the parts before assembly (and before installing inserts) to be sure that you have a good fit and proper contact. Test fit again after installing the inserts.

Install the M3 threaded inserts into all the parts that require them. The Hero Me Base will have at 26 holes that need M3 threaded inserts. Extruder mounts will use two to four M3 threaded inserts.

Other parts that use the inserts are the Hotend Mounts, some Part Cooling ducts, some ABL wings or brackets, and some Gantry Adapters and Gantry Clips.

For the Hero Me Base, install M3 threaded inserts in all the round holes. Do the same for the hotend and extruder mounts. DO NOT put an insert in the filament path of any part.

There are two new threaded insert holes on the top of the Hero Me Gen7 Base. These are deep, with the M3 insert hole inset within the wider hole; you want the inserts to be flush with the lower

ledge. The top area needs to be clear so that the round tabs of the hotend mounts to mate and allow the Base and Mount to be flush with each other.

There are several great YouTube videos that show the correct way to install the threaded inserts into your parts. The following images show the proper placement of threaded inserts in the Base.

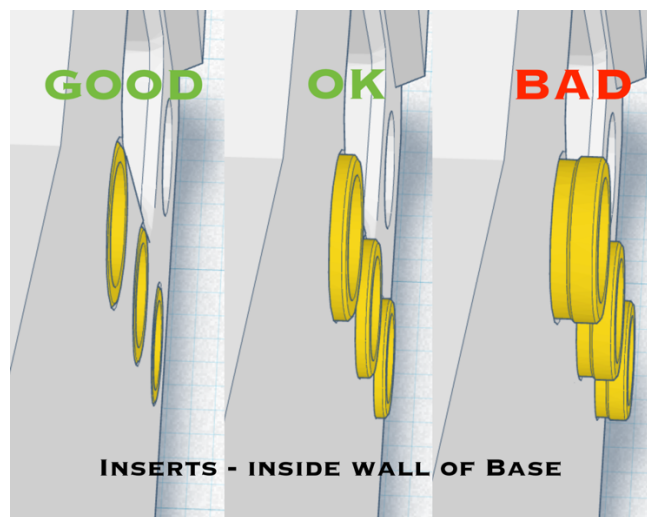
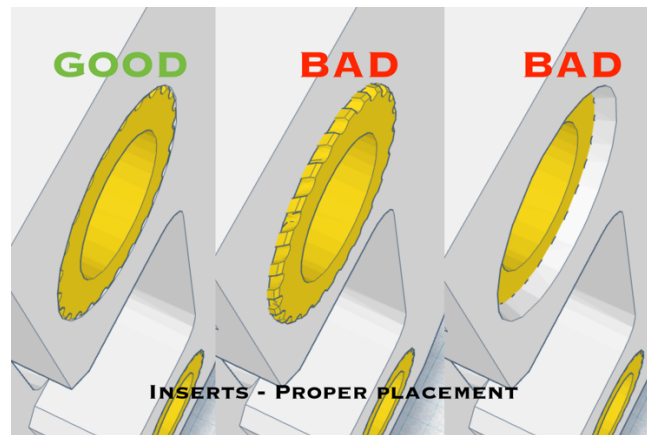
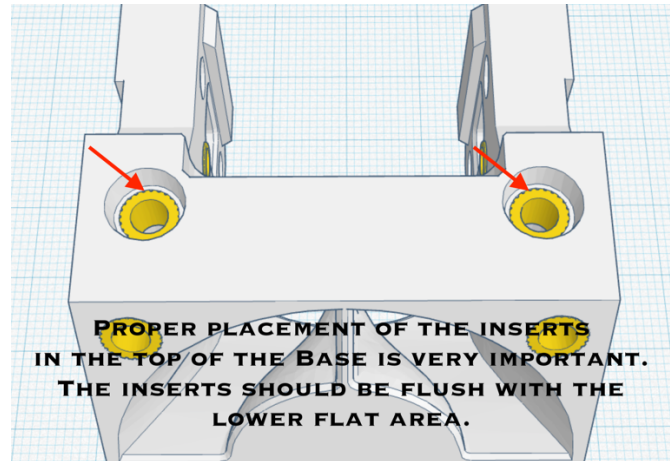

Here are images of where the threaded inserts are placed in the Hero Me Gen7 Base:

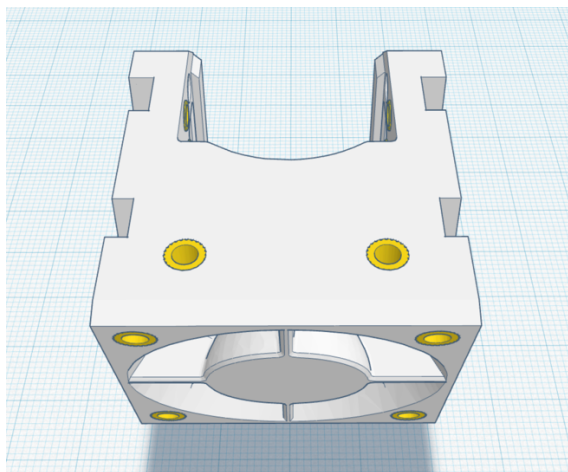
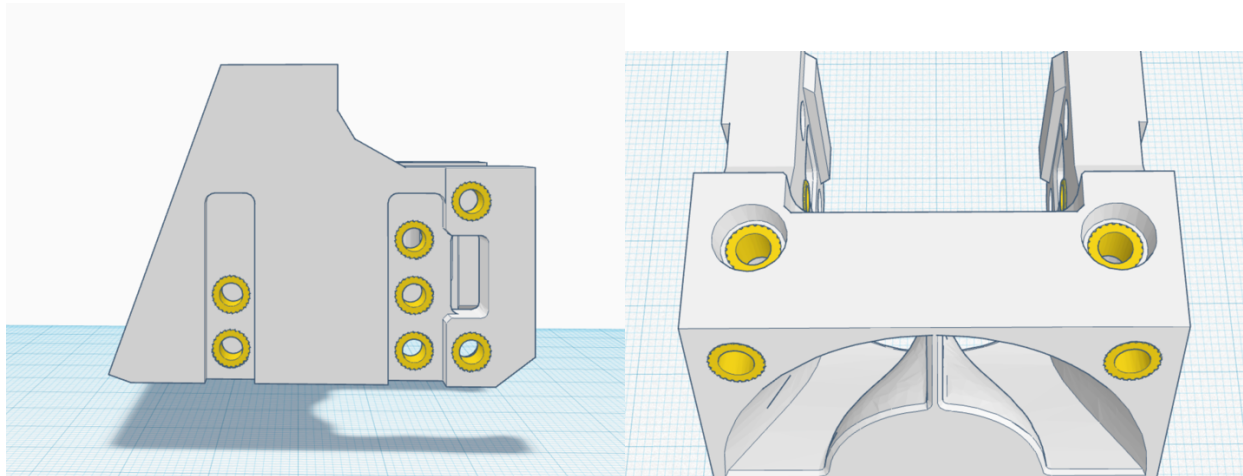
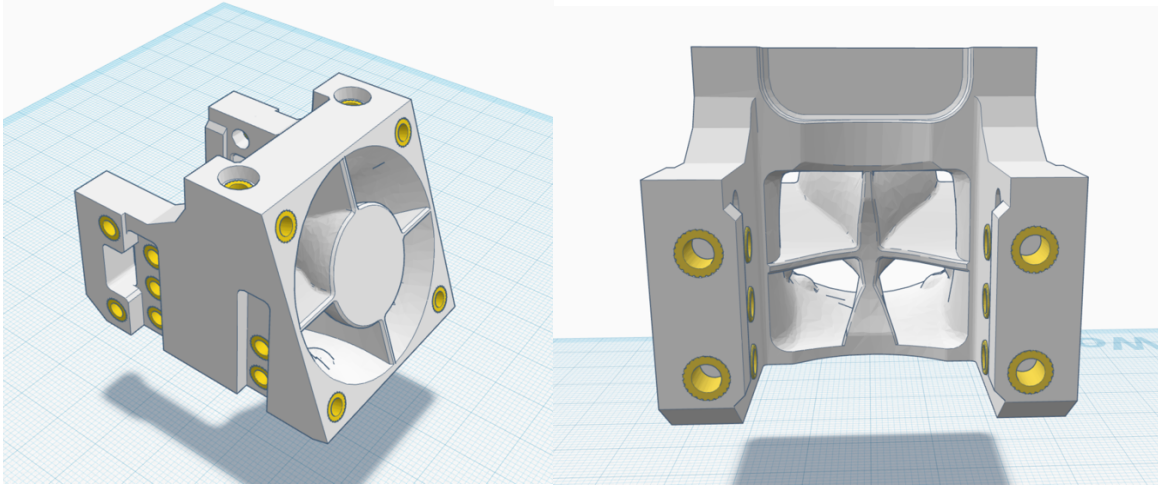

Disassemble current hotend assembly from the X carriage.

Prepare and make any adjustments, wiring changes, fan changes or additions, or any other changes needed on you hotend wire loom before assembling the Hero Me Gen7 cooling system. Some setups may require the X carriage to be partially or fully removed from the X axis gantry.

Hero Me Gen7 Assembly

Before assembly, 'dry fit' all the parts to be sure they will seat properly. During this step take any needed measurements for a PTFE tube to be cut and placed in the Hotend assembly stack, from inside the hotend's heat sink, through the hotend mount(s), riser (if needed), direct drive mount, and into the bottom of the extruder (if used).

For MediaMan3D patrons at the All-Access tier (or higher), I have created a half hour video covering the steps to assemble the Hero Me Gen7 setup. <https://www.patreon.com/posts/hero-me-gen7-two-74554580>

Below are the assembly steps with images that help show the assembly of the Hero Me Gen7 system to your X carriage. While your specific parts may be very different, they all follow the same basic pattern.

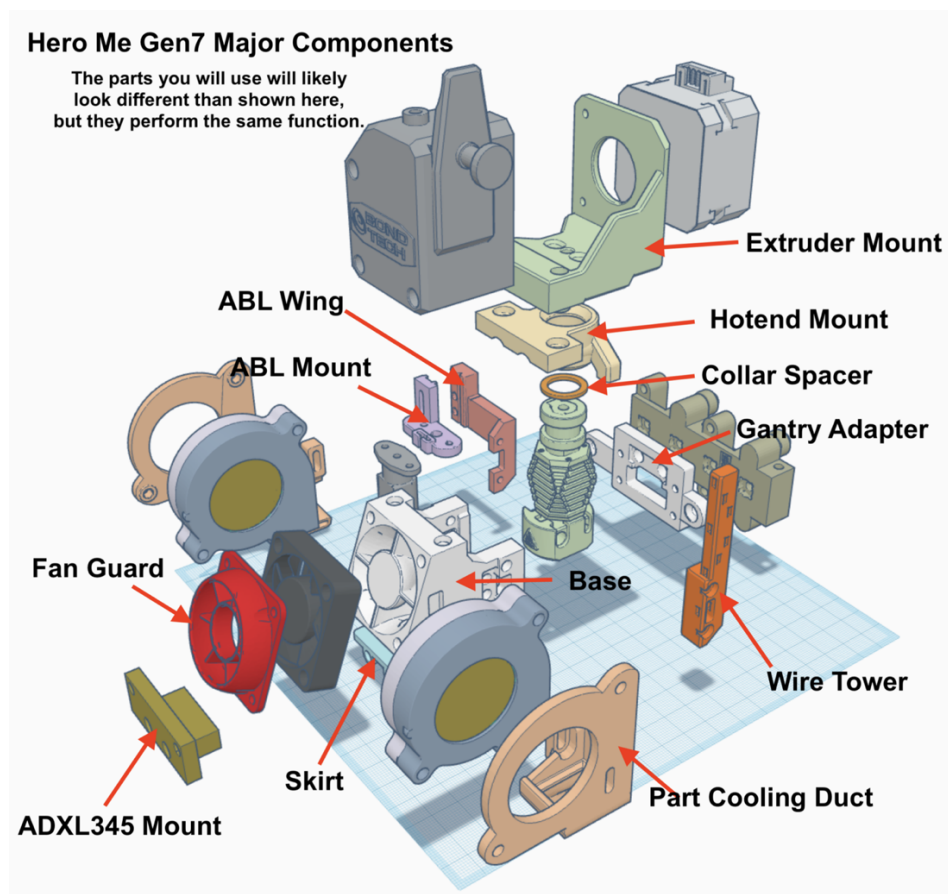

Exploded view with parts named. This example shows a Dragonfly BMO, Bondtech BMG, dual 5015 fans, and a BLTouch mounting to an Exoslide X carriage.

Start the assembly by attaching the Skirt to the bottom of the Base with 2 M3 screws.

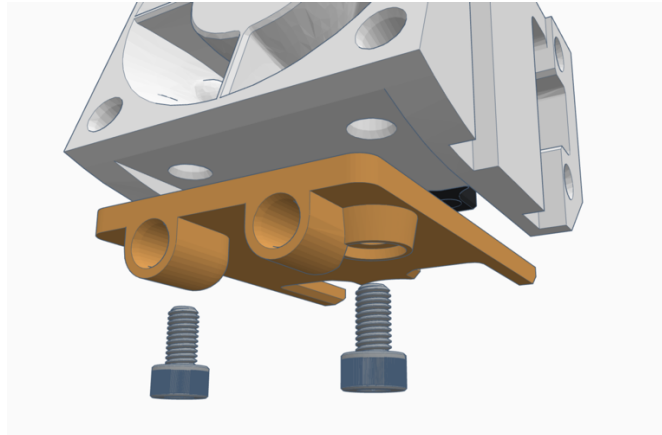

Next, attach the part cooling duct(s). Do not add the fans to the ducts yet.

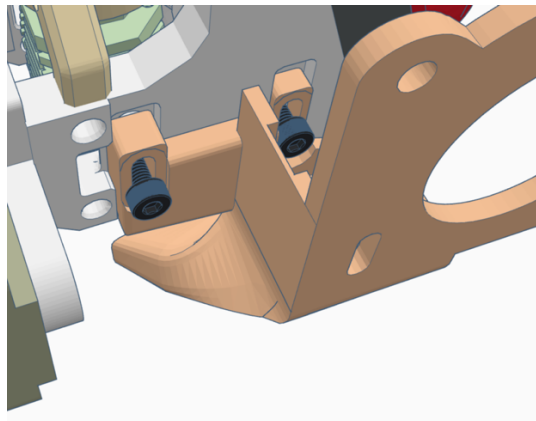

Before attaching the fans to the ducts, if used, attach the ABL bracket and sensor mounts and ABL sensor.

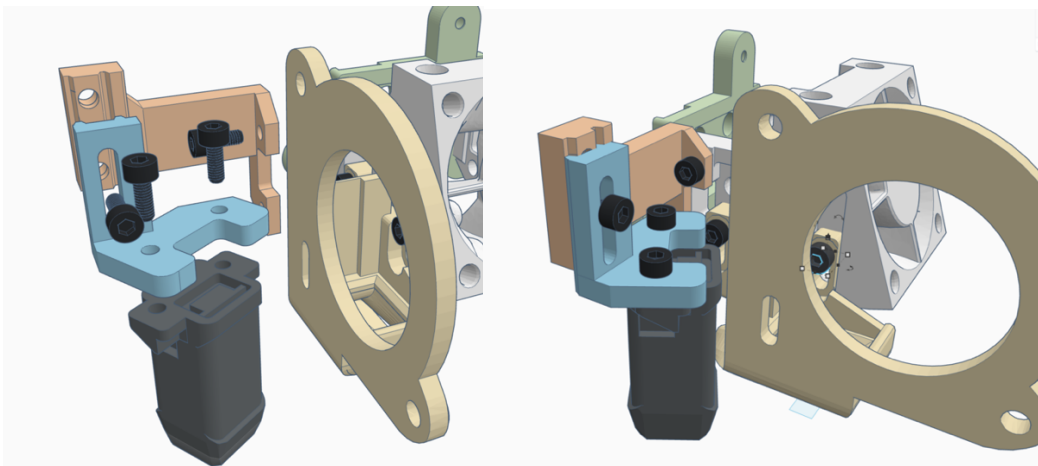

Then attach the part cooling fan(s) to the ducts. But only secure the front fan mount points in this step of the assembly. They will be added later.

In a few instances, the hot-end and its mount will need to be assembled after the Hero Me Base and Gantry Adapter have been attached to the X carriage. This is due to some X carriages only having a need mount point that is within the width of the Hero Me body.

Be sure to check your setup to see if a gantry mount point is behind where the hotend will be placed, if so, they this will have to be done before the hotend is inserted into the Base and mounted to its mount plate. Note that for collar/groove mount based hotends, there is a new retaining system. The E3DV6/Clone mount use two threaded inserts in the back of the collar.

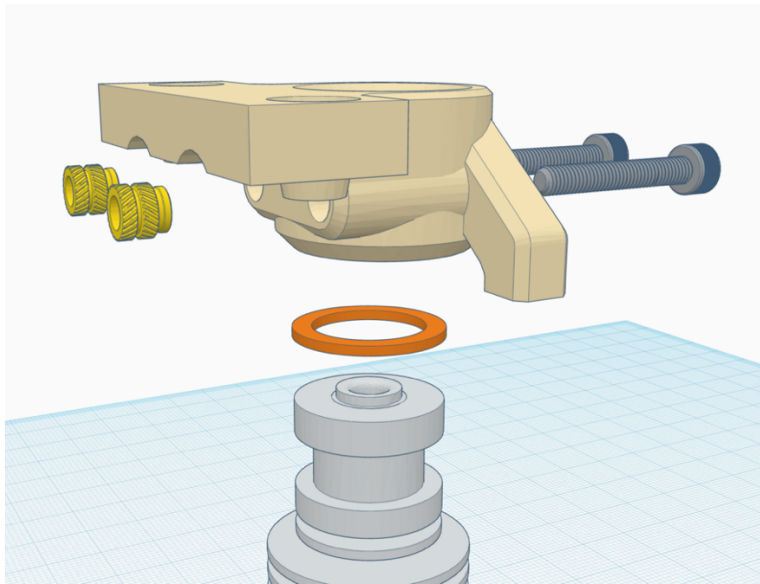

The hotend is prevented from moving by the M3 screw threads that 'dig in' to the sides of the collar, preventing it from dropping or spinning in place. Because there are different heights of the collar rings on hotends that are V6 style, I provide four different spacers (1mm to 2.5mm in thickness). The E3DV6 and true clones will use one 1mm spacer placed in the collar before inserting the hotend. You will want to test fit your hotend with screws to find the spacer that is correct for your hotend such that the screws are contacting the underside of the top ring on the collar.

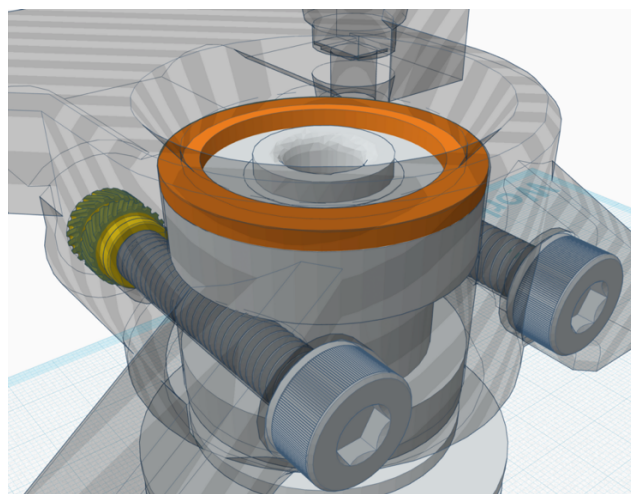

Assemble the hotend into its mount. Mount the hotend assembly to the Base.

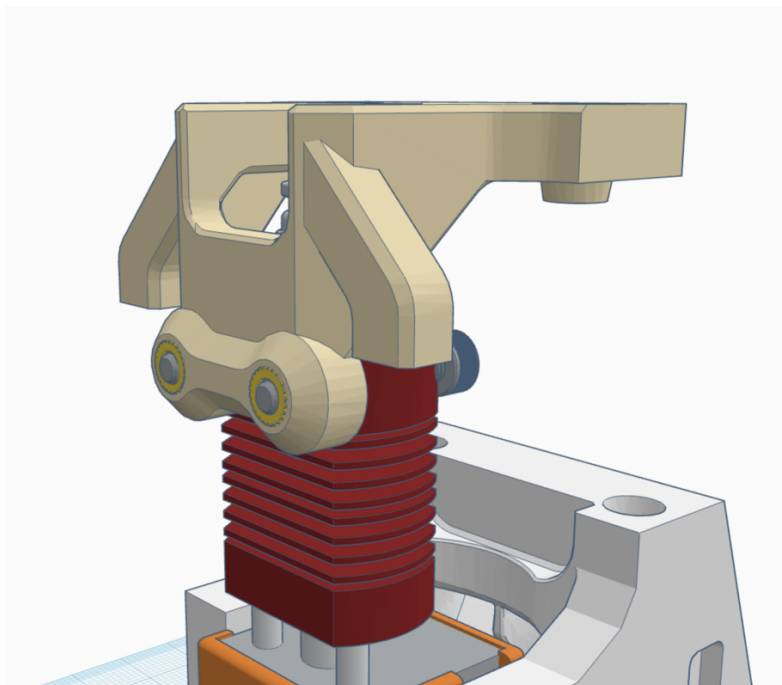
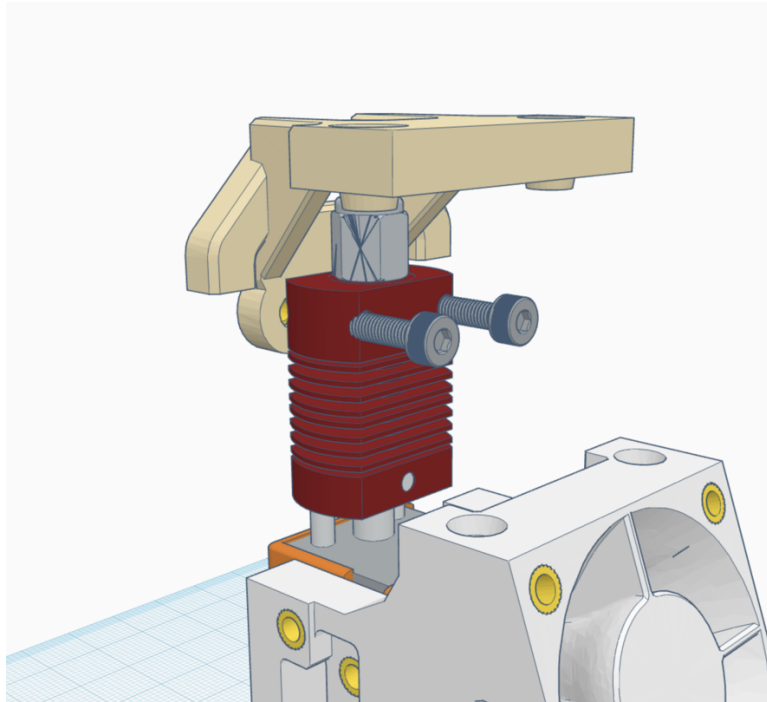

It is very important to note that hotends that used to connect to the X carriage with two M3 screws, no longer do. They are secured to the Hotend mount only. Screws do not continue to the X carriage.

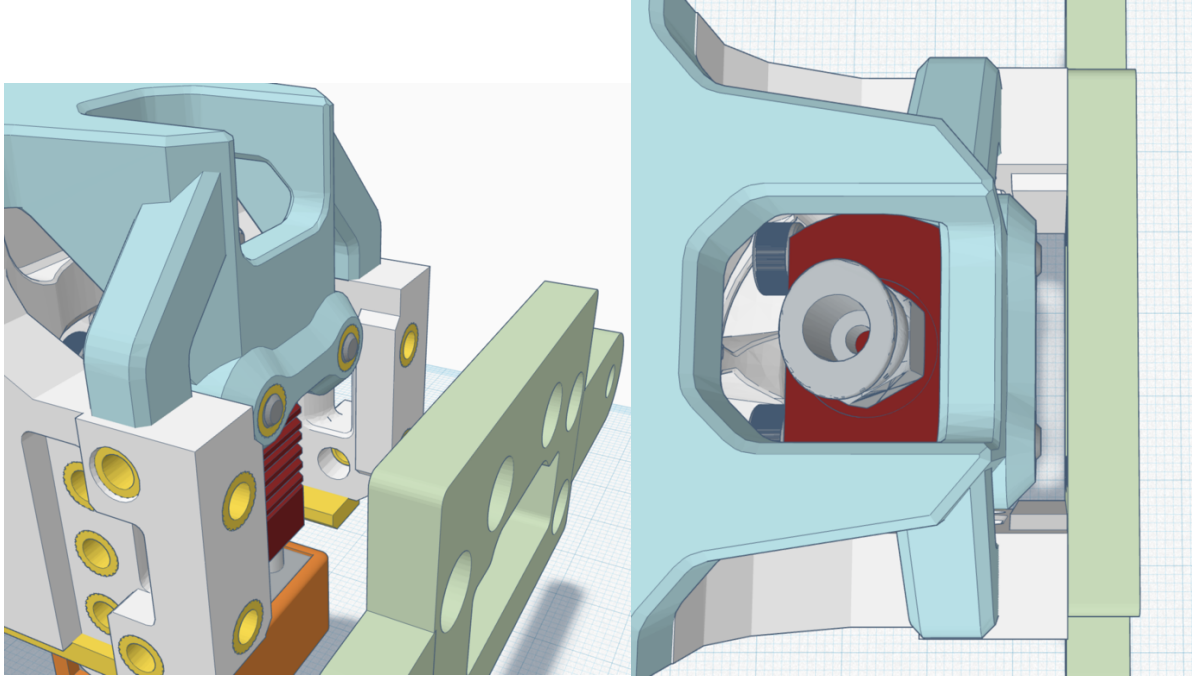

If direct drive, skip this step. If your setup will be Bowden based, now add two M3 screws into the top of the hotend mount to secure it to the Base.

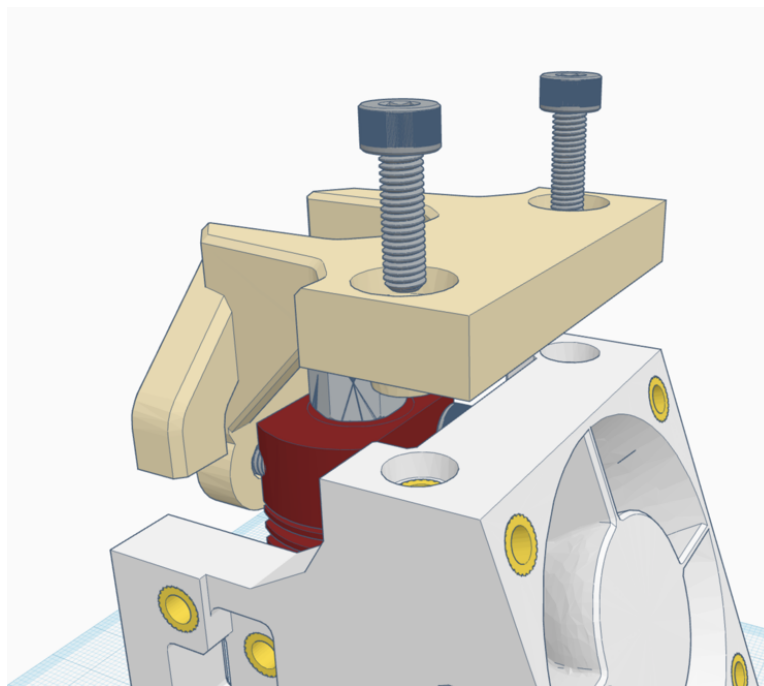

As there is no 'chimney' in the Gen7 Base, you will want to route the wires out the back left or right side of the base (behind where the fans mount. Wire management tower STLs are connected to either the new left or the right rear mount points. Note that an ABL bracket can be mounted on either the left or right side of the base using these same mount points. The tower and ABL mount can be 'stacked' on one side if needed.

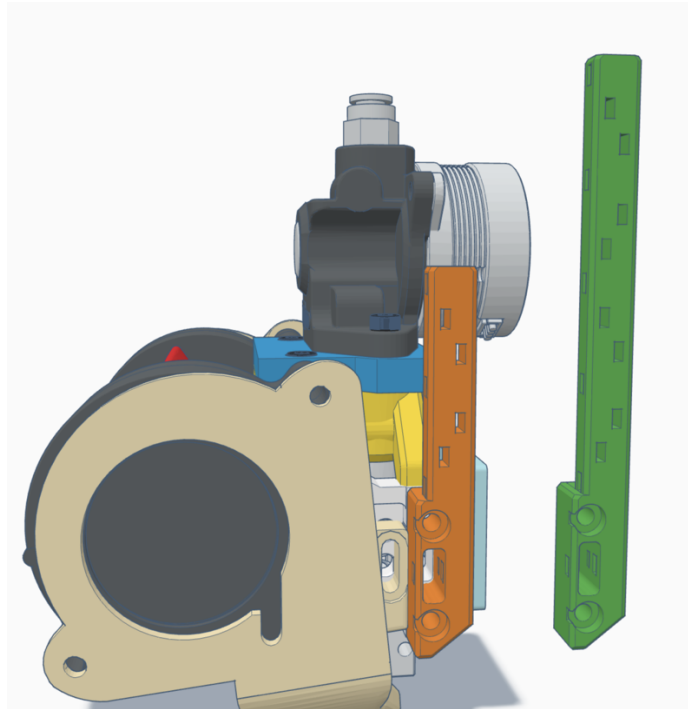

In addition to the 'Front' and 'Rear' versions of most extruder mounts. There are also optional 'riser' STLs (4mm, 6mm, 10mm) that can be using if needed to raise the height of the extruder/stepper in a rear mount setup, so that the stepper clears over the top of the X carriage.

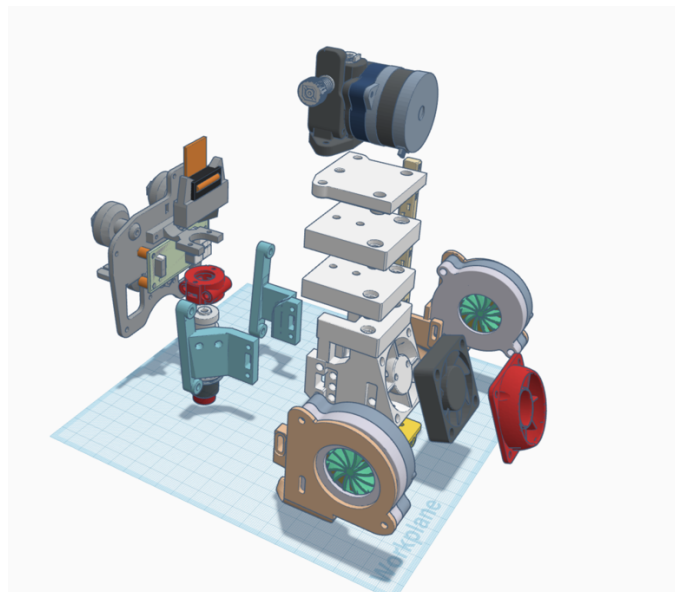

If needed place any riser(s) between the hotend mount and the extruder mount so that a rear facing stepper will clear above the top of a tall X carriage.

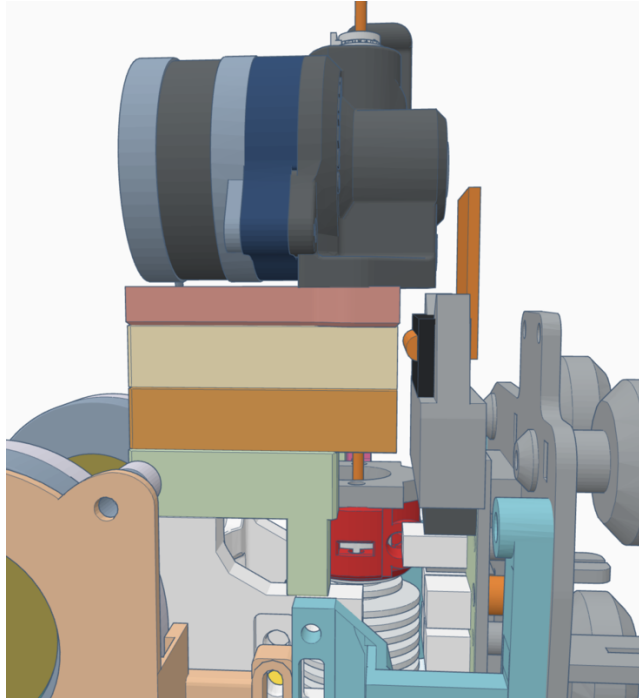

Some extruders must be secured to their mount plate before attaching to the base assembly as their mount points are from under the bottom of the mount plate. Other extruders can be mounted later, as they connect from the top or sides of the mount plate. If the extruder mounts from underneath, once secured you will want to install the PTFE tube into the base assembly and then into the extruder base when securing it.

Attach the extruder mount to the top of the base and hotend mount assembly. Add two M3 screws into the top of the hotend/ extruder assembly. long enough to secure the extruder mount, risers, hotend and base together.

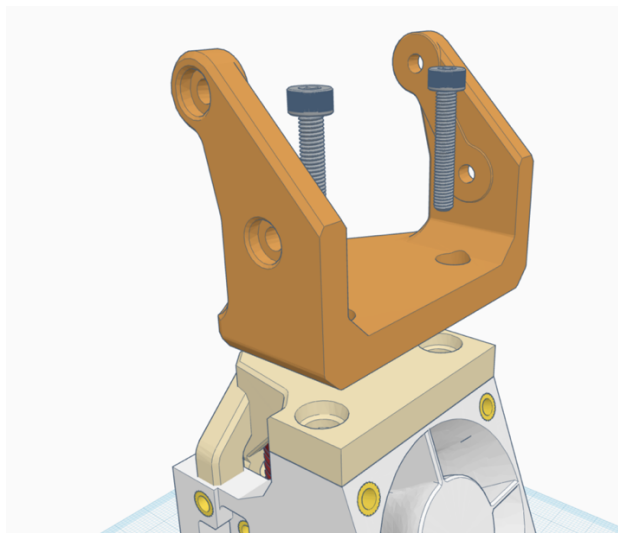

Attach the Gantry Adapter to the Base.

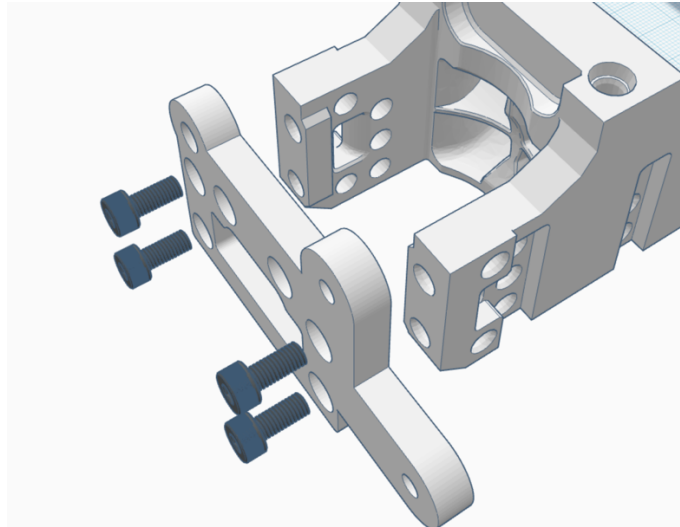

Mount the Hero Me assembly to your X carriage. Depending on your printer model, you may have to loosen or remove the X carriage from the X axis gantry to properly mount the Hero Me assembly to the X carriage.

Once the Hero Me assembly is attached to the X carriage, if needed reassemble the X carriage to the X axis gantry and adjust the printer's offset nut (V-Wheel setups) so that the whole assembly rides smoothly on the rail with no play/slop.

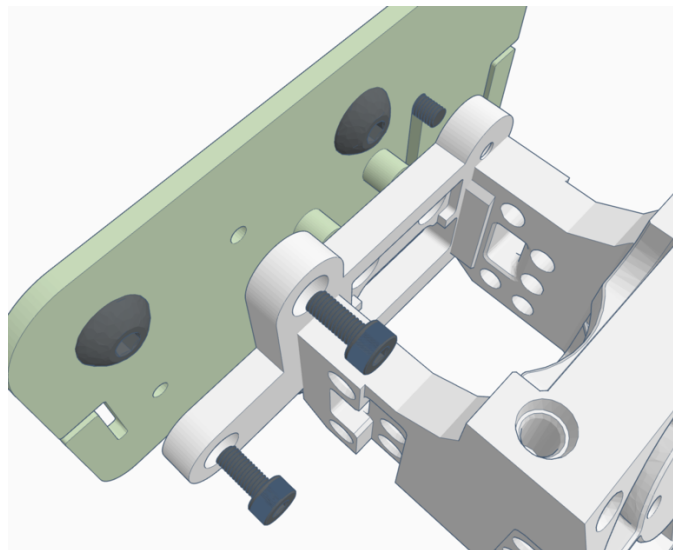

Attach the heat sink fan and shroud (if any) to the front of the Base.

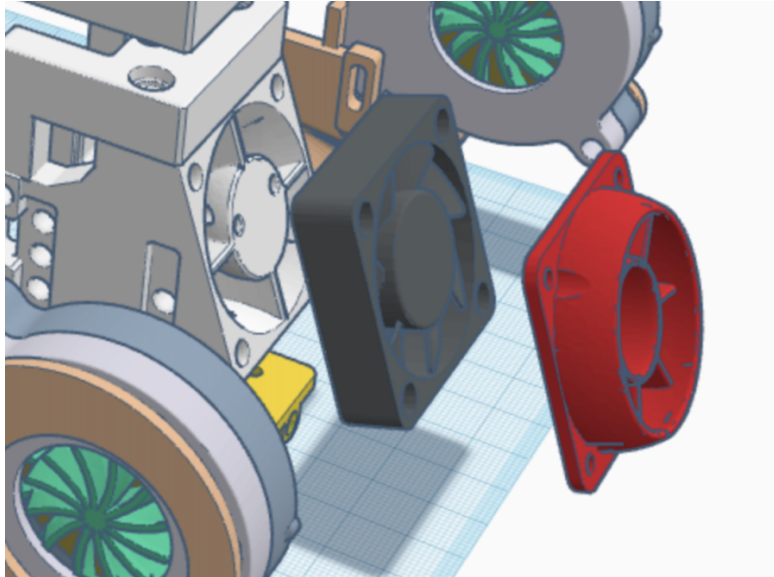

Optionally attach an ADXL345 mount and PCB if used and mount that to the front of the Skirt. Optionally add an LED bar between part cooling ducts (only valid for dual fan setups).

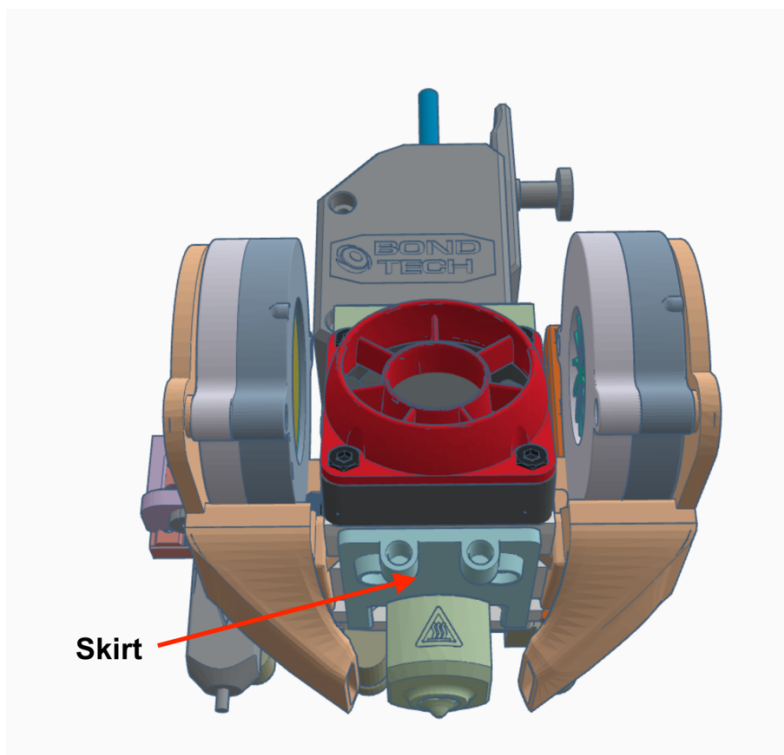

If you attached the fan(s) with both screws, you would need to temporarily remove the rear screw(s) and loosen (but do not remove) the front screws of the part cooling fan(s). Tip the fan(s) forward to provide access to the part cooling duct screws.

Adjust the height of the part cooling ducts to be 1.6mm above the build surface when the nozzle is touching the build plate.

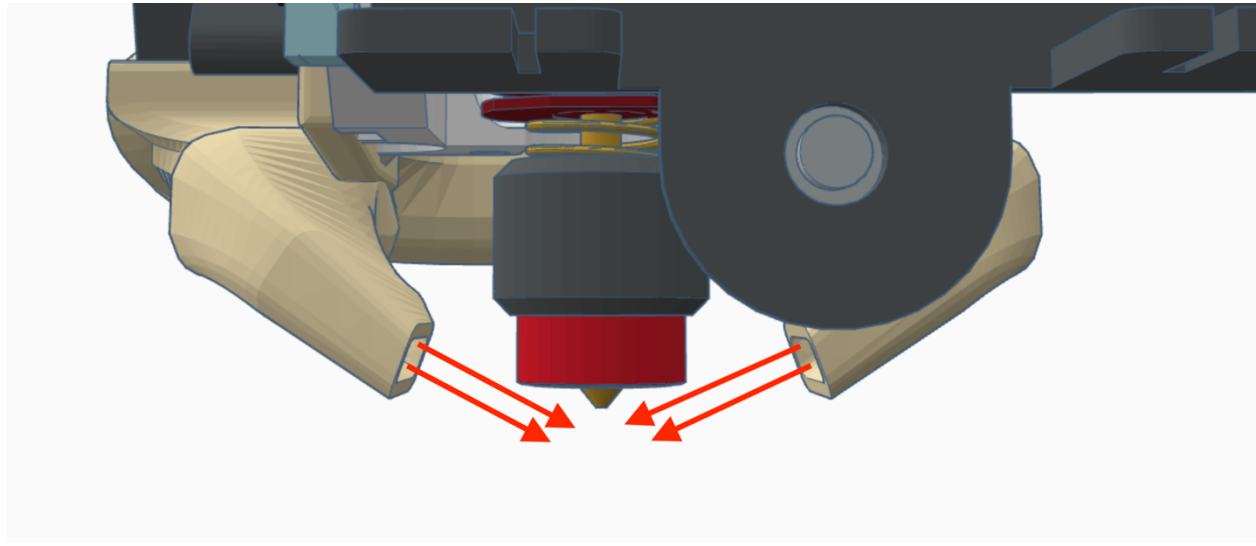

While the left fan (if used) is still tipped forward, roughly adjust the ABL sensor (if used) to be the right height above the bed in relation to the nozzle.

Return the fans to the proper position and secure/tighten the M3 screws for the fan(s).

The following image shows the correct placement of the Part Cooling Duct tips in relation to the nozzle. Note that the nozzle is NOT centered vertically between the ducts. At first glance it may seem incorrect, but this positioning is correct.

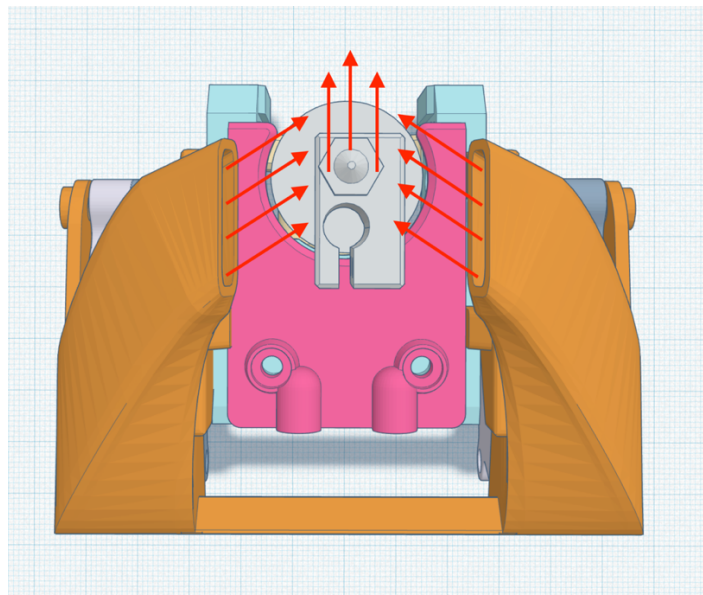

The ducts are channeled to direct the airflow at an angle (upside down Y shaped) to maintain a laminar air flow at the part below the nozzle to greatly reduce turbulence.

Perform cable management and any final wiring.

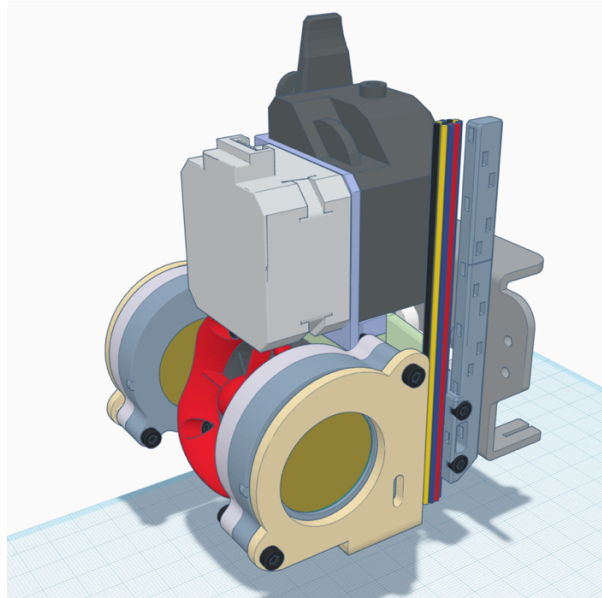

ABL Sensor offsets for Firmware or GCODE

Check that everything is secure and where it belongs. And before you print... You will need to set your printer's Home offset (not to be confused with the ABL sensor offset). The Gantry Adapters for the Hero Me move the hotend's nozzle forward -9mm from the original position.

This move was necessary to allow the Hero Me Gen7 to be compatible with the most printers, hotends, ABL sensors, and fans. The nozzles of all the supported hotends are in the same position in the Hero Me Gen7, allowing the parts cooling ducts to all be accurately designed to cool the part directly below the nozzle tip. The cooling ducts have been CFD calibrated and real-world tested to perform to the optimum.

Optional: If you have an ABL sensor, adjust the height of the sensor to the specs provided by the manufacturer. Based upon your printed parts and how the Hero Me is assembled, your setup may vary slightly. To get the best results for your printer, measure your setup's X, Y offsets from the tip of your nozzle to the tip (or center) of your ABL sensor (rounded to the nearest integer). If the ABL is mounted on the left, the X distance in mm will be a negative value for the firmware offset. If mounted on the right side of the hotend, the X distance offset will be a positive number. The Y axis may have a positive or negative number.

The Marlin setting for the ABL offset can be made in firmware, but it also can be done via GCode.

The firmware setting can be edited/added to the configuration.h file. You would add the following line and replace the X and Y values with the ones you measured for your ABL sensor.

```
#define X_PROBE_OFFSET_FROM_EXTRUDER -50; -distance of probe in whole mm
left of the nozzle example only
#define Y_PROBE_OFFSET_FROM_EXTRUDER -10; -front of nozzle, example only
```

Or you can set the ABL sensor offsets in GCode via your slicer software. Add the following line and replace the X and Y values with the ones you measured to the Start GCode in your slicer's settings:

```
M851 X-50 Y-10 ; ABL Sensor offsets - example only
```

The detailed instructions for Marlin firmware and GCode on setting the ABL offset are here:

<https://marlinfw.org/docs/gcode/M851.html>

The Home setting can be made in firmware, but it also can be done via GCode. For Marlin, the Home offset setting can be edited/added to the configuration.h file. Based upon the Gantry Adapter you are using, you would add one of these two lines in the configuration.h file, then recompile and upload to your printer.

```
#define MANUAL_Y_HOME_POS -9
Or
M206 X -46, Y +2 X -37, Y -2; example only
```

Or, you can set the Home offset setting via your slicer software. Based upon the Gantry Adapter you are using, you would add this line to the Start GCode in your slicer's settings:

```
M206 Y-9; Y axis offset
```

In case these values do not place the hotend's nozzle just inside the edge of the build plate when homing the Y axis, you can adjust the Y offset value up or down to work for your setup.

The Marlin firmware detailed instructions on setting the printer's Home offset is here:

<https://marlinfw.org/docs/gcode/M206.html>

To set the edge boundaries when performing a mesh bed level use G29 to set the area to be probed. Here is an example for a bed that is 235mm by 235m:

```
G29 B205 F20 L20 R205
```

Where:

'B' is the back limit of the probing grid.

'F' is the front limit of the probing grid

'L' is the left limit of the probing grid

'R' is the right limit of the probing grid

The detailed instructions on G29 is:

<https://marlinfw.org/docs/gcode/G029-abl-bilinear.html>

Once you have set the Home offset, perform your printer's bed leveling process.

3D Printer Model Specific Notes

Ender 5 Pro/Plus

When using 5015 fans on the Ender 5 Pro/Plus you will need to reposition the front crossbar down by 40mm to ensure access to the full Y axis build space (and to not crash into the crossbar when homing the printer). Dropping the crossbar has another benefit, full easy view of the first layer of prints that were blocked by the Ender 5 Pro/Plus top frame. Moving the crossbar down by 40mm will have no negative affect on frame strength. There are several mods for this both commercial and free to print. You can search for 'Ender 5 Crossbar' or 'crossbar relocation' in Thingiverse.com and come up with at least a half dozen options.

Here are links to a few STL sets:

<https://www.thingiverse.com/thing:4410969>

<https://www.thingiverse.com/thing:4485125>

<https://www.thingiverse.com/thing:4912123>

<https://www.printables.com/model/100469-ender-5-front-crossbar-relocator>

<https://www.thingiverse.com/thing:3876601>

There is also an issue with some Ender 5 Plus printers, in that with some hotend setups (not just Hero Me Gen6) the hotend can collide with the stock bed rod holders. Bondtech has created parts to replace the stock bed rod holders that fix this issue. While they sell them, they also offer the STLs for free:

Bed Rod Holder Set for Ender-5 Plus

<https://www.bondtech.se/product/ddx-bed-rod-holder-set-ender-5-plus/>

Bed Rod Holder Set for Ender-5 Plus (Free STLs)

https://www.bondtech.se/downloads/STL/Creativity/Bed_rod_holder_for_Ender-5-Plus.STL

If you have any Ender 5 series and are using any of the ABL sensor mounts, you may need to use a spacer to clear the metal clip that holds the belt on the left side. This applies to both the OEM gantry plate and the PrinterMods.com MDD plate. The spacer file is: Ender_5_ABL_Spacer.stl and is found in the ABL Mounts/Other ABL Sensors/ folder. The firmware offset for the Y axis will increase by -6 (spacer width).

Hero Me Gen7 Orientation and Assembly Videos

If you are a MediaMan3D patron at the All-Access tier (or higher) you have access to the Hero Me Gen7 STL parts orientation and assembly videos via these Patreon posts:

<https://www.patreon.com/posts/hero-me-gen7-stl-74555664>

<https://www.patreon.com/posts/hero-me-gen7-two-74554580>

Please let me know if you find issues with this assembly process or have a better way to do it. These are the basic steps, and there will be some esoteric assemblies that may need a very different process due to the unique nature of the setup (e.g., Anycubic Vyper setup).

Please provide feedback on anything Hero Me Gen7 related via the #hero-me-gen7 or #hmg7-support channels in the Hero Me Discord server. Be sure to review the #gen7-faqs channel first before posting your question as it may already be answered.

Thanks and Credits

I would especially like to thank James Tongue (Hangtight) and Craig West (ACWest) for their contributions to the development of the Hero Me Gen7 master Suite.

James has rebuilt much of the Hero Me Gen7 components into STEP format and Craig for providing the part cooling ducts. The cooling ducts have been CFM tested and validated to have the optimum focused airflow across the part at the tip of the nozzle.

Thank you for choosing the Hero Me Gen6 to be part of your 3D printing experience! Please post a make or remix on the Hero Me Gen7 Printables.com project page and/or post a make to one of the many 3D printer Facebook groups. Tell your 3D printing friends about the Hero Me Gen7!

Printables.com: <https://www.printables.com/model/39322-hero-me-gen7-master-suite>

Thank you,

Andy
MediaMan3D

Twitter: <https://twitter.com/mediaman3D>

YouTube: <https://www.youtube.com/@MediaMan3D>

Print Shop: https://www.cubee3d.com/store/Merlin_Media (Custom Print Shop)

3D Design Library: <https://www.printables.com/social/56045-mediaman3d/>

Affiliates: Wham Bam Systems: <https://whambam3d.com?aff=48>

Or use this coupon code at checkout: **MediaMan2022**

Patronage:

<https://www.patreon.com/MediaMan3D>

<https://www.buymeacoffee.com/MediaMan3D>